

# Data logging and control

# BADENIA 2

## QUICK LINKS

- [Overview](#)
- [Product Variant Matrix](#)
- [LED Indicator Definitions](#)
- [Dimensions](#)
- [Installation](#)
- [Connector Information](#)
- [CN1](#)
- [CN2](#)
- [Recycling and Environmental Protection](#)

# BADENIA 2

## Overview

- 20 x analogue inputs
- 4 x independent CAN ports
- Fast 1GB Ethernet connectivity
- 4GB logging memory

The Badenia 2 from Cosworth offers high-rate data logging, control, outputs and huge processing capabilities. Featuring up to 20 x analogue inputs, 4 x CAN ports, LIN, and 5 x digital inputs, the Badenia 2 is an extremely capable data logger.

Additionally, a selection of HSD/PWM outputs result in the Badenia 2 being the ideal unit for complete vehicle control.



Electrical Data	
Operating Voltage	6.6 to 31.5V
Current Consumption	572mA @ 14V
Communication	
Ethernet	1x 1000MB/s 2x 100MB/s
CAN Ports	4 x Independent CAN Ports Max BAUD rate; 1MBit/s 64 x Message Buffers per Port Software selectable 120Ω Resistor
LIN Ports	2 x LIN Bus Master
EtherCAT	1 x EtherCAT Master
Serial Ports	2 x Bi-Directional RS232 Ports Split Tx and Rx Rates Max BAUD Rate: 115200
Serial Debug Ports	1 x Bi-Directional RS232 Fixed@115200 BAUD Rate
Mechanical Data	
Size	118 x 120 x 34 mm
Weight	472 grams
Environmental	IP66
Material	6802-T6 Anodized
Vibration	Cosworth DV-V (C)
Operating Temp	-20°C to + 70°C
Storage Temp	-20°C to + 80°C

I/O	
Logging Specifications	<a href="#">See Token Logging Options</a>
Analogue Inputs	20 x 0-5 Inputs 16 bit resolution Filtered 3dB freq of ~15.9kHz 2.1M Ω Impedance AIN 1-8 selectable 1K8 Pull Up
Digital Inputs	4 x High Freq (10kHz) supports hall effect /VRS/DF11i 1 x Support IR Lap Timing & Switches Selectable 3k3 pull-up to 5V or Level Shift for Passive Sensors
Excitations	3 x 5V ±0.25% Supply @ 100mA 2 x Software Selectable 5V/12V 12V ±0.5% Supply @ 700mA
HSD / PWM	2 x HSD / PWM Battery voltage @ 700mA(max) 400Hz Maximum PWM Frequency
Motion Sensor	Accelerometer 3 axis ±16G
Internal Monitoring	Battery Voltage Box Temperature Excitation Voltage
LEDs	7 x System Status LEDs

# BADENIA 2

## Product Variant Matrix

### Token Logging Options

Variant	220	240	260
Part Number	01P-650100-220	01P-650100-240	01P-650100-260
Capacity (MB)	1,024	2,048	4,096
Cont. Sampling Rate (Hz)	1,000	1,000	1,000
Cont. Bandwidth (bytes/sec)	50,000	50,000	100,000
High Speed Sampling Rates (Hz)	-	2,000	5,000
High Speed Bandwidth (bytes/sec)	-	48,000	100,000
No. of Burst Logging Tables	1	1	1
Total no. of Channels	1,024	1,024	2,048
Maths Channels	100	200	500
Logic Channels	Enabled	Enabled	Enabled
Analogue Inputs	8	12	20
Digital Inputs	5 (4x Df11i)	5 (4x Df11i)	5 (4x Df11i)
CAN Ports	2	3	4
LIN Ports	2	2	2
Ethernet Displays	48	48	48
Auto Coding Customer	Upgrade Option	Upgrade Option	Upgrade Option
Auto Coding Developer	Upgrade Option	Upgrade Option	Upgrade Option
Telemetry Tables	-	-	1

### Ordering Information

Description	Part Number
Badenia 2 Series	01L-650100
220 Token	01P-650100-220
240 Token	01P-650100-240
260 Token	01P-650100-260
Auto Coding Developer Token	On Request

### Compatible Devices

Compatible Devices	
CDU 4.3	01D-640030
CDU 7.0	01D-640040
CDU 10.3	01D-640060
Centaurus 5 Mk2	01L-610140
RLU	01L-650030
SJU	01L-650050
CCW Mk2	01D-641150

### Software Information

	Pi Toolset	Configuration software for power control and logging (v8 and above)
	Pi Toolbox	Professional Data Analysis
	Auto-Coding via MATLAB/Simulink®	Customer auto-coding are available via MATLAB/Simulink® and Cosworth Workspace Editor

# BADENIA 2

## LED Indicator Definitions



Legend	Function	Sequence	Period
	No Power to the Unit	Off	Grey bar
	Initialising and waiting for clock sync	On	Red bar
	Unit operational	50% Flash (1Hz)	Red bar with grey gaps
	During startup a single flash LED test	Long Single Pulse	Red bar with grey gap
	Normal running operation	Off	Grey bar
	Logger error or no dataset loaded	On	Red bar
	During startup a single flash LED test	Long Single Pulse	Red bar with grey gap
	Normal running operation	Off	Grey bar
	Logger full and overwriting data	On	Red bar
	1000Base T, No connection established	Off	Grey bar
	Connection established	50% Flash (1Hz)	Green bar with grey gaps
	Communication active	Flickering	Green bar with grey gaps
	100Base T, No connection established	Off	Grey bar
	Connection established	50% Flash (1Hz)	Green bar with grey gaps
	Communication active	Flickering	Green bar with grey gaps
	100Base T, No connection established	Off	Grey bar
	Connection established	50% Flash (1Hz)	Green bar with grey gaps
	Communication active	Flickering	Green bar with grey gaps
	EtherCAT, No connection established	Off	Grey bar
	Connection established	50% Flash (1Hz)	Green bar with grey gaps
	Communication active	Flickering	Green bar with grey gaps

# BADENIA 2

## Dimensions

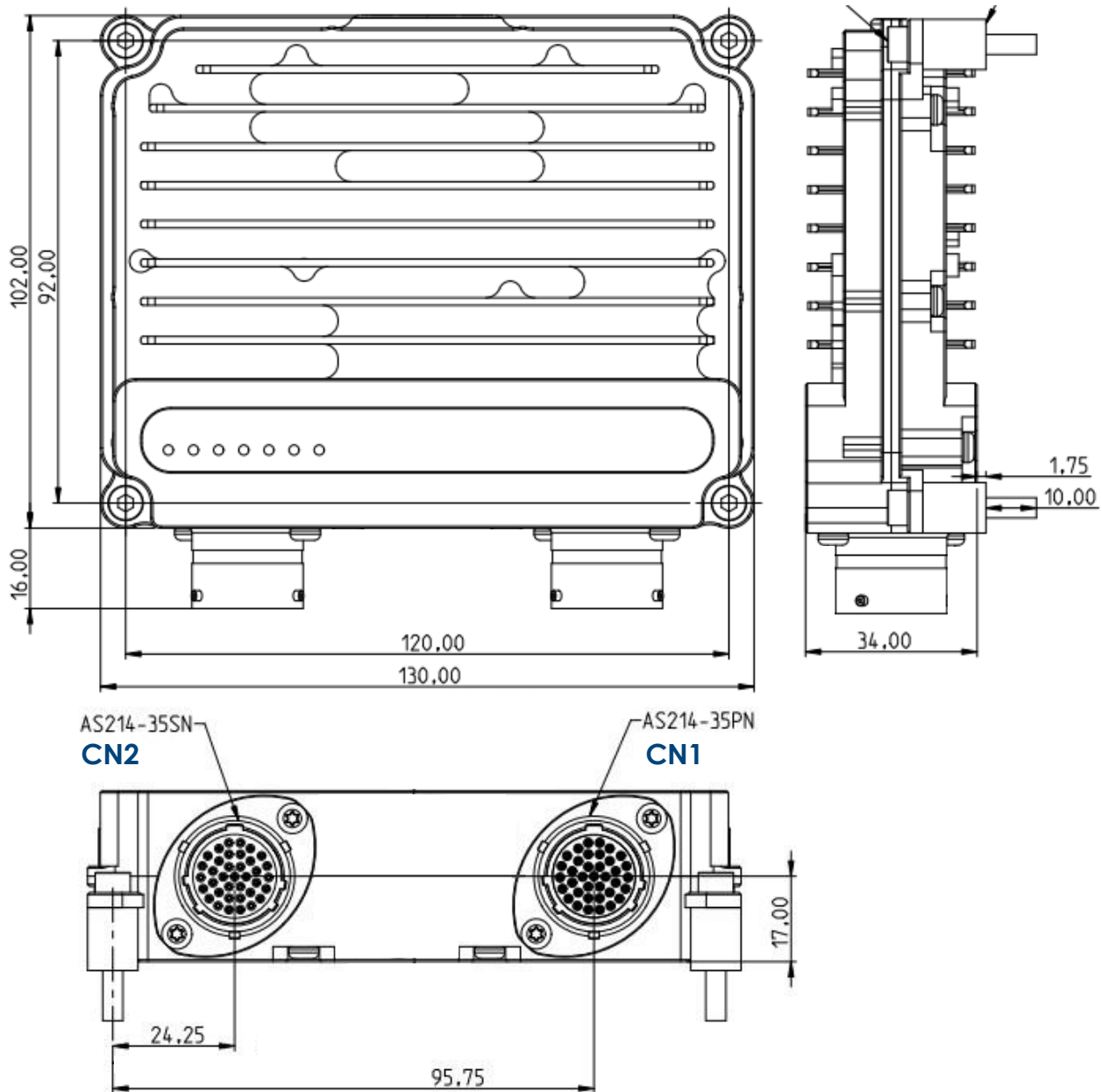

## Installation

- Ensure unit is protected against severe vibrations by mounting using supplied AV mounting kit. Also ensure unit is not fouling other structures which may experience severe vibrations
- Ensure unit is positioned in an area with sufficient cooling air flow to prevent over heating
- Ensure unit is mounted away from sources of electrical interference
- Ensure unit is mounted in position where unit will not come into contact with liquid

# BADENIA 2

## Connector Information

Please note, pin allocation is in functional order not pin number order.

## CN1

Connector	Mating Connector
AS214-35PN	AS614-35SN

Pin	220	240	260	Description
6	BATT+	BATT+	BATT+	Battery supply +VE
22	BATT+	BATT+	BATT+	
7	BATT-	BATT-	BATT-	Battery supply -VE
5	ETH1000+1	ETH1000+1	ETH1000+1	Ethernet 1000BaseT +ve for PC comms
4	ETH1000-1	ETH1000-1	ETH1000-1	Ethernet 1000BaseT -ve for PC comms
3	ETH1000+2	ETH1000+2	ETH1000+2	Ethernet 1000BaseT +ve for PC comms
21	ETH1000-2	ETH1000-2	ETH1000-2	Ethernet 1000BaseT -ve for PC comms
20	ETH1000+3	ETH1000+3	ETH1000+3	Ethernet 1000BaseT +ve for PC comms
2	ETH1000-3	ETH1000-3	ETH1000-3	Ethernet 1000BaseT -ve for PC comms
1	ETH1000+4	ETH1000+4	ETH1000+4	Ethernet 1000BaseT +ve for PC comms
19	ETH1000-4	ETH1000-4	ETH1000-4	Ethernet 1000BaseT -ve for PC comms
15	ETH1-RX+1	ETH1-RX+1	ETH1-RX+1	Ethernet 100BaseT for car comms RX+
14	ETH1-RX-1	ETH1-RX-1	ETH1-RX-1	Ethernet 100BaseT for car comms RX-
28	ETH1-TX+1	ETH1-TX+1	ETH1-TX+1	Ethernet 100BaseT for car comms TX+
16	ETH1-TX-1	ETH1-TX-1	ETH1-TX-1	Ethernet 100BaseT for car comms TX-
12	ETH2-RX+2	ETH2-RX+2	ETH2-RX+2	Ethernet 100BaseT for car comms RX+
26	ETH2-RX-2	ETH2-RX-2	ETH2-RX-2	Ethernet 100BaseT for car comms RX-
27	ETH2-TX+2	ETH2-TX+2	ETH2-TX+2	Ethernet 100BaseT for car comms TX+
13	ETH2-TX-2	ETH2-TX-2	ETH2-TX-2	Ethernet 100BaseT for car comms TX-
30	CANH1	CANH1	CANH1	CAN port 1
18	CANL1	CANL1	CANL1	
29	CANH2	CANH2	CANH2	CAN port 2
17	CANL2	CANL2	CANL2	
34	N/A	CANH3	CANH3	CAN port 3
35	N/A	CANL3	CANL3	
24	N/A	N/A	CANH4	CAN port 4
33	N/A	N/A	CANL4	
11	N/A	N/A	N/A	Do Not Connect
25	N/A	N/A	N/A	
10	LIN1	LIN1	LIN1	LIN bus master 1
9	LIN2	LIN2	LIN2	LIN bus master 2
36	RS232-TX1	RS232-TX1	RS232-TX1	RS232 serial comms transmit data (Badenia to external)
32	RS232-TX2	RS232-TX2	RS232-TX2	RS232 serial comms transmit data (Badenia to external)
37	RS232-RX1	RS232-RX1	RS232-RX1	RS232 serial comms receive data (external to Badenia)
31	RS232-RX2	RS232-RX2	RS232-RX2	RS232 serial comms receive data (external to Badenia)
8	DEBTX	DEBTX	DEBTX	Debug comms transmit data
23	DEBRX	DEBRX	DEBRX	Debug comms receive data

# BADENIA 2

## Connector Information

Please note, pin allocation is in functional order not pin number order.

## CN2

Connector	Mating Connector
AS214-35SN	AS614-35PN

Pin	220	240	260	Description
26	AIN1	AIN1	AIN1	8 x Analogue inputs Software selectable 1K8 pull-up resistor Input filter 234kHz ADC filter response 22.5kHz 0 to 5v input with 16 bit resolution
12	AIN2	AIN2	AIN2	
25	AIN3	AIN3	AIN3	
11	AIN4	AIN4	AIN4	
9	AIN5	AIN5	AIN5	
10	AIN6	AIN6	AIN6	
8	AIN7	AIN7	AIN7	
24	AIN8	AIN8	AIN8	
7	N/A	AIN9	AIN9	12 x Analogue inputs Input filter 234kHz ADC filter 22.5kHz 0 to 5v input with 16 bit resolution
23	N/A	AIN10	AIN10	
22	N/A	AIN11	AIN11	
6	N/A	AIN12	AIN12	
21	N/A	N/A	AIN13	
5	N/A	N/A	AIN14	
20	N/A	N/A	AIN15	
4	N/A	N/A	AIN16	
2	N/A	N/A	AIN17	
3	N/A	N/A	AIN18	
1	N/A	N/A	AIN19	
19	N/A	N/A	AIN20	
17	DIGIN1	DIGIN1	DIGIN1	4 x Digital inputs DF1 Ii, Selectable 3k3 pull-up to 5v or level shift for passive sensors
18	DIGIN2	DIGIN2	DIGIN2	
36	DIGIN3	DIGIN3	DIGIN3	
30	DIGIN4	DIGIN4	DIGIN4	
35	DIGIN5	DIGIN5	DIGIN5	Digital input level. IR lap timing and switches. 3k3 pull-up
16	HSD1	HSD1	HSD1	400Hz PWM maximum switching rate Switches between ground and battery voltage @700mA
29	HSD2	HSD2	HSD2	
13	EXT5PSU1	EXT5PSU1	EXT5PSU1	3 x 5v excitation @100mA
14	EXT5PSU2	EXT5PSU2	EXT5PSU2	
27	EXT5PSU3	EXT5PSU3	EXT5PSU3	
15	EXT5/12PSU1	EXT5/12PSU1	EXT5/12PSU1	2 x 5v or 12v software selectable excitation 5v @ 100mA, 12v @ 700mA
28	EXT5/12PSU2	EXT5/12PSU2	EXT5/12PSU2	
31	Sensor GND	Sensor GND	Sensor GND	5 x Grounds These are all common connections which can be used for any ground connection
32	Sensor GND	Sensor GND	Sensor GND	
33	Sensor GND	Sensor GND	Sensor GND	
34	Sensor GND	Sensor GND	Sensor GND	
37	Sensor GND	Sensor GND	Sensor GND	

## Recycling and Environmental Protection

Cosworth Electronics is committed to conducting its business in an environmentally responsible manner and strive for high environmental standards.

### Manufacture

Cosworth products comply with the appropriate requirements of the Restriction of Hazardous Substance (RoHS)

### Disposal

Electronic equipment should be disposed of on accordance with the regulations in force and in particular on accordance with the Waste in Electrical and Electronic Equipment directive. (WEEE).

### Battery

This equipment contains a rechargeable battery (Manganese Silicon Lithium).

The equipment may be returned to Cosworth Electronics for a replacement battery. A charge will be made for this service.

To remove the battery for recycling:

- Remove the case(s).
- Remove printed circuit boards from the case.
- Remove the battery from the printed circuit board.
- Dispose of the battery in accordance with the regulations in force.

Removal of the battery will result in the warranty of the unit being void.





**T (UK)** +44 (0) 1954 235 600 | **T (US)** +1 (317) 644 1037  
**E** [sales@cosworth.com](mailto:sales@cosworth.com) | [www.cosworth.com](http://www.cosworth.com)

---

© Copyright Cosworth Electronics Ltd | All Content is  
Proprietary and Confidential. Brookfield Technology Centre,  
Twentyence Road, Cottenham, Cambridge, CB24 8PS.